

J320R282-4200

Drawing

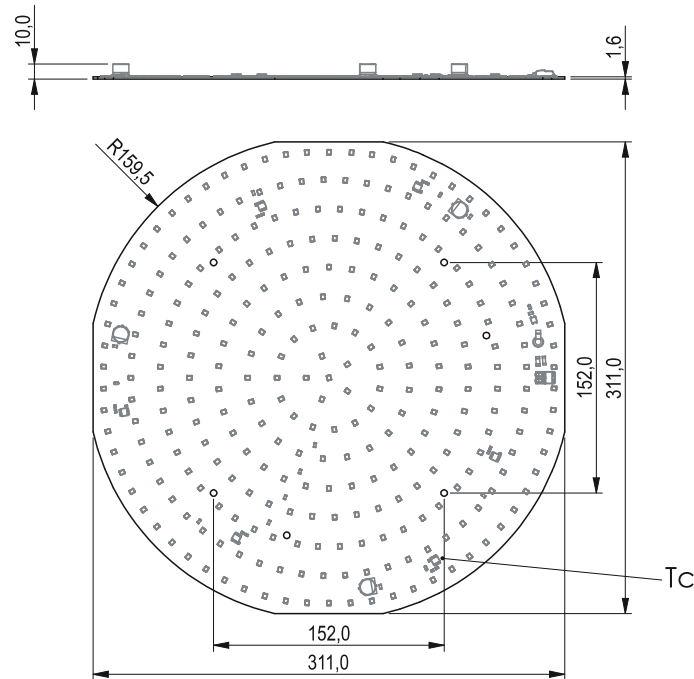

Technical data

Nominal voltage	230 VAC
Power factor	>0,80
Ambient temperature range	-25 ... +45 °C
tc	85 °C
tp rated	45 °C
Lumen maintenance L80B10	60000 h
Lumen maintenance L70B50	>72000 h
Insulation	Reinforced
Insulation test voltage	3000 V
Classification acc. to IEC 62031	Built-in
Risk group (IEC 62471)	RG1
Type of protection	IP00
Beam characteristic	120 °
Surge protection L-N	1 kV
SVM	0
P _{st} LM	<1

Product details

- Replacement for CFL
- Driver on board
- Zero flicker
- Compact slim design
- Non dimmable
- High reliability
- Optimised design for luminous flux
- High quality of light thanks to low modulation
- 5 year guarantee

J320R282-4200

Product code	Photometric code	Useful luminous flux at tp=25 °C	Expected luminous flux at tp rated	Power consumption	Efficacy at tp=25 °C	Expected efficacy at tp rated	Energy classification
J320R282-827	827/359	4100 lm	4050 lm	25 W	164 lm/W	162 lm/W	C
J320R282-830	830/359	4150 m	4100 lm	25 W	166 lm/W	164 lm/W	C
J320R282-840	840/359	4200 lm	4150 lm	25 W	168 lm/W	166 lm/W	C
J320R282-927	927/359	3500 lm	3450 lm	25 W	140 lm/W	138 lm/W	D
J320R282-930	930/359	3550 lm	3500 lm	25 W	142 lm/W	140 lm/W	D
J320R282-940	940/359	3700 lm	3650 lm	25 W	147 lm/W	146 lm/W	D

Thermal details

Temperature has a great influence on the lifetime of LED products. Exceeding the permissible temperatures can significantly shorten the life of the module or even lead to its destruction. It is necessary to verify compliance with the maximum allowable temperature at the reference point under stable operating conditions. The maximum value should be determined based on the application-specific worst-case conditions. Both reference point temperatures (tc and tp) are measured at the same location.

Installation

The LED modules are designed for direct mains operation (230 V AC). Installation must be carried out under observation country specific relevant safety regulations and standards. The module is suitable for luminaires of protection class I, grounding is mandatory to comply with safety standards. In case of applications in luminaires of protection class II the safety regulations acc. to luminaire safety standards must be observed. An additional protection against direct touch (test finger) to the light emitting side of the module has to be guaranteed. This is typically achieved by means of a non removable light distributor over the module or by a suitable luminaire construction.

Risk of sulfurization

The LED uses a silver-plated lead frame and its surface color may change to black (or dark colored) when it is exposed to sulfur (S), chlorine (Cl) or other halogen compound. Sulfurization of lead frame may cause intensity degradation, change of chromaticity coordinates and, in extreme cases, open circuit. It requires caution. Due to possible sulfurization of lead frame, the LED Modules should not be used and stored together with oxidizing substances made of materials such as rubber, plain paper, lead solder cream, etc.

Wiring type and cross section

The wiring can be in stranded wires or solid with a cross section of 0.2 to 0.75mm².

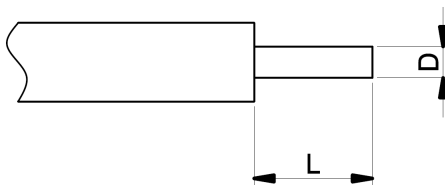

D - wire cross section	Min	Max
	0,2mm ²	0,75mm ²
L - strip length	Min	Max
	7,5mm	9,5mm

Photometric code

1 digit	2+3 digit	4 digit	5 digit	6 digit
CRI	Colour temperature in Kelvin x 100	MacAdam initial	Mac Adam after 25 % of the lifetime (max. 6000 h)	Luminous flux after 25% of the lifetime (max. 6000 h)
7 70-79				7 ≥ 70
8 80-89				8 ≥ 80
9 ≥90				9 ≥ 90